

71-8734-250
7/06

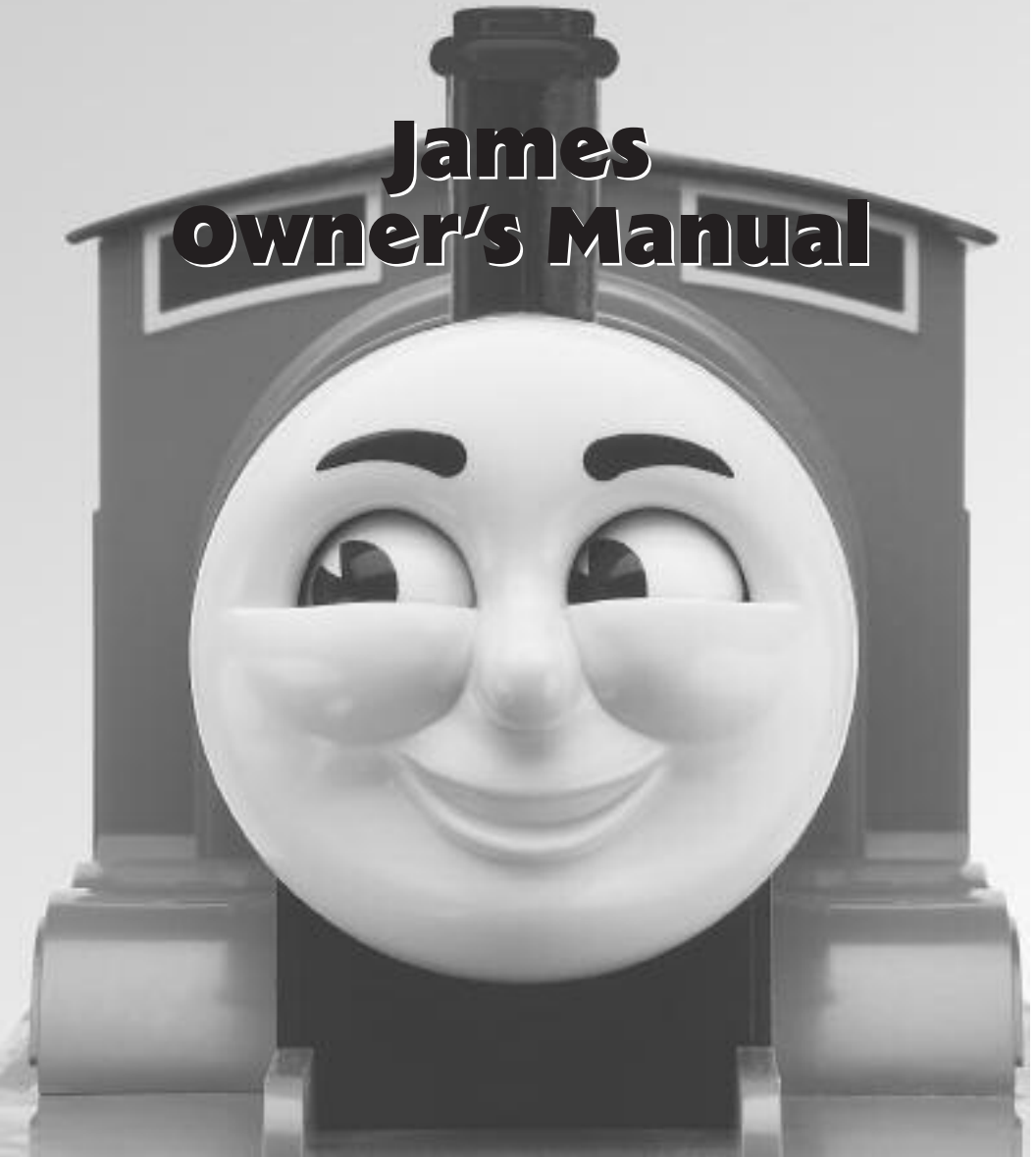

James Owner's Manual



Congratulations!

Congratulations on your purchase of James! With moving eyes and an operating whistle, James is happy to join Thomas & Friends™ for adventures around your layout.

Features of this locomotive

- Transformer controlled forward, neutral and reverse operation
- Moving eyes
- Operating whistle
- Fixed coupler on rear of tender
- Powerful maintenance-free motor
- Set of three removable faces
- Removable roof

Table of contents

Running your engine

Running your engine	3
Coupling	3
Sounding your locomotive's whistle	4
Attaching the three faces	5
Reverse unit procedure	6

Maintaining and servicing your engine

Lubricating your locomotive	7
Limited Warranty/Lionel Service	8

The following Lionel marks may be used throughout this instruction manual and are protected under law. All rights reserved.

Lionel®, *TrainMaster®*, *Odyssey®*, *RailSounds®*, *CrewTalk™*, *TowerCom™*, *DynaChuff™*, *StationSounds™*, *Pullmor®*, *ElectroCoupler™*, *Magne-Traction®*, *CAB-1® Remote Controller*, *PowerMaster®*, *Lionel ZW®, ZW®*, *PowerHouse®*, *TMCC®*, *Lionelville™*, *Lockon®*, *Wireless Tether™*, *LionMaster®*, *FatBoy™*, *American Flyer®*, *TrainSounds™*

The name FasTrack® is used with permission from Pitsco, Inc.

Thomas the Tank Engine & Friends™

CREATED BY BRITT ALLCROFT



Based on The Railway Series by The Reverend W Awdry. © 2006 Gullane (Thomas) Limited. Thomas the Tank Engine & Friends and Thomas & Friends are trademarks of Gullane (Thomas) Limited. Thomas the Tank Engine & Friends & Design is Reg. U.S. Pat. & Tm. Off.

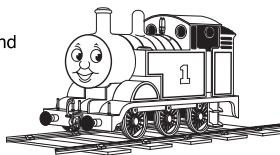

Visit the Thomas & Friends™ web site at www.thomasandfriends.com

Running your engine

Running your engine

1

With track power off, place your locomotive and tender on the track.

Refer to the following section for information on coupling the cars.

2

Couple the locomotive to the tender.

Fit the tab on the locomotive drawbar into the tender drawbar and plug-in the tether as illustrated in Figure 1.

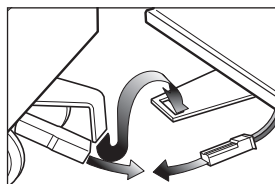

Figure 1. Drawbar and tether connections

3

Power up your locomotive with your transformer.

Your locomotive is designed to operate on 7-15 volts alternating current. Virtually all Lionel and Lionel-compatible alternating-current transformers are suitable.

Note!

Do not power your locomotive with direct-current (DC) transformers. The locomotive was designed for use with alternating-current (AC) transformers only.

4

Move 'em out!

Get your locomotive moving. Your locomotive goes through a repeating pattern of operations: forward, neutral, reverse, neutral, and so on. To sequence the reverse unit, press the DIRECTION button on your transformer, or briefly bring the throttle all the way back to the OFF position and then forward. Each press of the DIRECTION button or interruption in track power causes the locomotive to advance to the next operational state.

Adjust track voltage until your locomotive moves at your desired speed.

Coupling

Your locomotive's tender features a fixed coupler. To couple your locomotive to your rolling stock, open the magnetic coupler on the rolling stock and slide the couplers together. To couple two fixed couplers, simply raise one of the cars and lower the coupler into place.

Running your engine

Sounding your locomotive's whistle

Press the WHISTLE button on your controller to sound the locomotive's whistle. Be sure that the whistle ON/OFF switch is in the ON position. Refer to Figure 5 on page 6 for the location of that switch.

If your controller does not have a WHISTLE button, install a Lionel Sound Activation Button (available separately, part no. 610-5906-001). Connect the button as shown in Figure 2.

If you would like to disable the whistle sounds, throw the whistle ON/OFF switch to the OFF position.

Note! All track power must feed through the Sound Activation Button. Do not bypass the button.

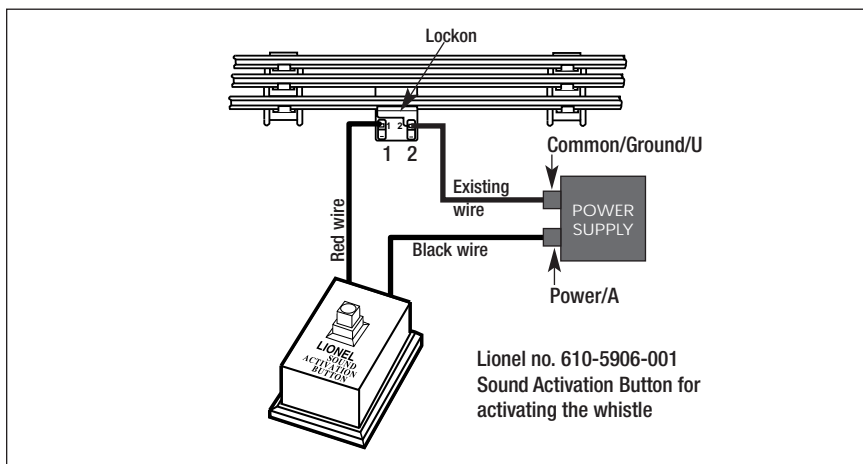

Figure 2. Sound Activation Button wiring

Note! The no. 610-5906-001 button works with any Lionel AC transformer except no. 6-4690 Type MW.

Running your engine

Attaching the three faces

Three interchangeable facial expressions easily slip on and off for fun and imaginative play. Refer to Figure 3.



Figure 3. Interchangeable faces

To attach one of the faces, carefully position it in front of the permanent smiling James face and push it straight on. To remove it, simply pull it straight off. Please remember that the smiling James face cannot be removed. Refer to Figure 4.

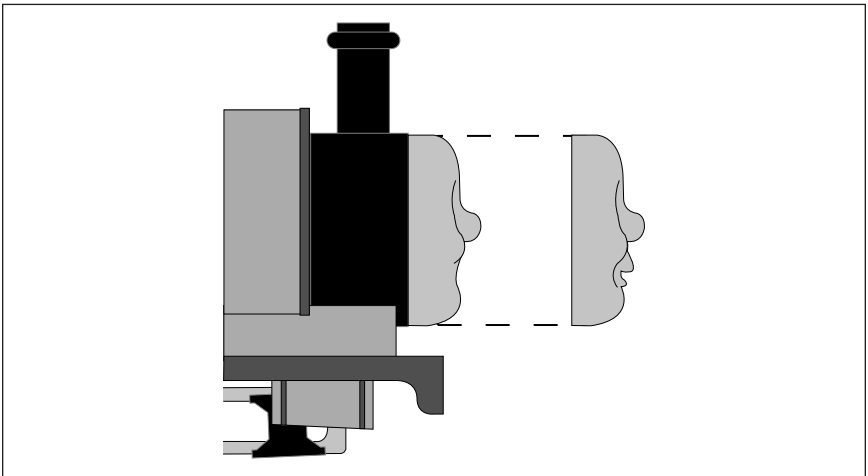

Figure 4. Attaching the faces

Running your engine

Reverse unit procedure

The electronic reverse unit inside your Lionel locomotive acts like the transmission in a car. When you apply power to the track, the locomotive moves in the direction specified by the reverse unit—or it sits in neutral, awaiting another power interruption. Power interruptions are the signal that tells the reverse unit to sequence to the next operational state.

To interrupt power and sequence the locomotive's reverse unit, press the direction control button or briefly bring the throttle lever all the way back to the OFF position. The reverse unit alternates between three states: forward, neutral, and reverse.

Also, the locomotive can be “locked” into a certain mode of operation by throwing the reverse unit switch (see Figure 5). To lock your locomotive into a specific operational state, sequence the locomotive into the desired state and reduce track power without completely powering down the locomotive, then throw the switch to the OFF position. The DIRECTION button will then have no effect on the direction of the locomotive. If you would like to resume forward-neutral-reverse operation, simply throw the reverse unit switch back to the ON position.

Additionally, this reverse unit has a “power-up reset” feature. If the locomotive sits without power for a short period of time, the reverse unit will automatically reset and start in the forward direction when the transformer is turned on or “powered up,” regardless of the reverse unit switch position. If the switch is in the OFF position, the locomotive will start in the forward direction and be “locked” there.

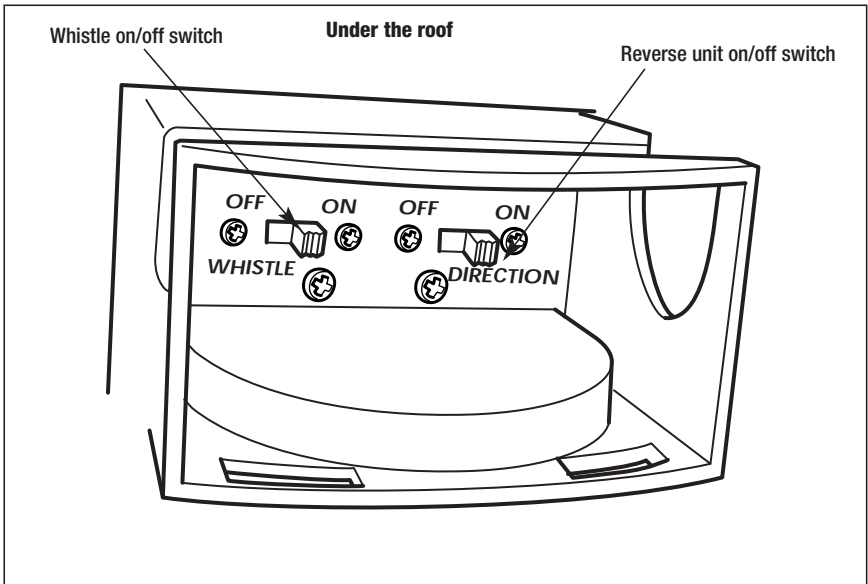

Figure 5. Switch locations

Maintaining and servicing your engine

Lubricating your locomotive

Help your steam locomotive lead a long and productive life on your railroad by maintaining it properly.

We recommend that you purchase a Lionel Lubrication and Maintenance Kit (6-62927), available from your Lionel dealer. Two basic rules to keep in mind: never over-lubricate (a small amount will do) and avoid getting grease or oil on the locomotive's wheels, contact rollers, or your track.

You'll know your locomotive requires lubrication when visual inspection reveals dryness on the parts indicated in Figure 6. Remove accumulated dirt and dust before lubricating, and always lubricate any locomotive emerging from prolonged storage.

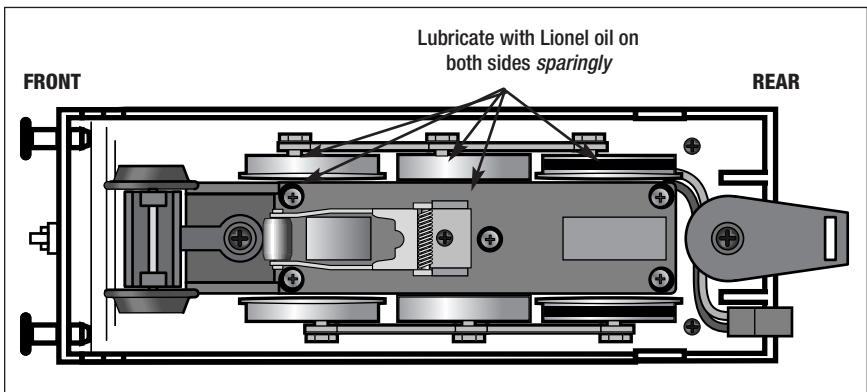

Figure 6. Lubrication points

Limited Warranty/Lionel Service

This Lionel product, including all mechanical and electrical components, moving parts, motors and structural components, except for light bulbs, is warranted to the original consumer-purchaser, for **one year** against original defects in materials or workmanship when purchased through an authorized Lionel merchant.

This warranty does NOT cover normal wear and tear, light bulbs, defects appearing in the course of commercial use, or damage resulting from abuse or misuse of the product by the purchaser. Transfer of this product by the original consumer-purchaser to another person voids this warranty. Modification of this product voids this warranty.

Any warranted product which is defective in original materials or workmanship and is delivered by the original consumer-purchaser to Lionel L.L.C. or an authorized Lionel L.L.C. Service Center, together with proof of original purchase will, at the option of Lionel L.L.C., be repaired or replaced, without charge for parts or labor. In the event the defective product cannot be repaired, and a replacement is not available, a refund of the original purchase price will be granted. Any products on which warranty service is sought must be sent freight or postage prepaid, as transportation and shipping charges are not covered by the warranty.

In no event shall Lionel L.L.C. be liable for incidental or consequential damages.

Some states do not allow the exclusion or limitation of incidental or consequential damages, so the above exclusion may not apply to you.

This limited warranty gives you specific legal rights, and you may have other rights which vary from state to state.

Instructions for Obtaining Service

If service for this Lionel L.L.C. product is required, bring the item, along with your dated sales receipt and completed warranty information to the nearest Authorized Lionel Service Center. Your nearest Lionel Service Center can be found by calling 1-800-4-Lionel, or by accessing our Website at www.lionel.com.

If you prefer to send your product back to Lionel L.L.C. for repair in Michigan, you must first call 586-949-4100 or FAX 586-949-5429, or write to Customer Service, P.O. Box 748, New Baltimore, MI 48047-0748, stating what the item is, when it was purchased and what seems to be the problem. You will be sent a return authorization letter and label to ensure your merchandise will be properly handled upon receipt.

Once you have received your return authorization and label, make sure that the item is packed to prevent damage during shipping and handling. We suggest that you use the product's original packaging. This shipment must be prepaid and we recommend that it be insured.

Please make sure you have followed all of the above instructions carefully before returning any merchandise for service. You may choose to have your product repaired by one of our Authorized Lionel Service Centers after its warranty has expired. A reasonable service fee will be charged.

Warranty Information

Please complete the information below and keep it, along with your dated sales receipt. You must present this and your dated sales receipt when requesting warranty service.

Name _____

Address _____

Place of Purchase _____

Date of Purchase _____

Product Number _____

Product Description _____



© 2006 LIONEL L.L.C., CHESTERFIELD, MI 48051-2493
UNITED STATES OF AMERICA
PRINTED IN CHINA